

FOOT MASTER[®] LEVELING CASTERS

The Original Since 1989



A Division of DoRodo[®]

FOOT MASTER® Leveling Casters

The Accomplishment of Perfect Product & Company + The Original Leveling Caster



CASTER

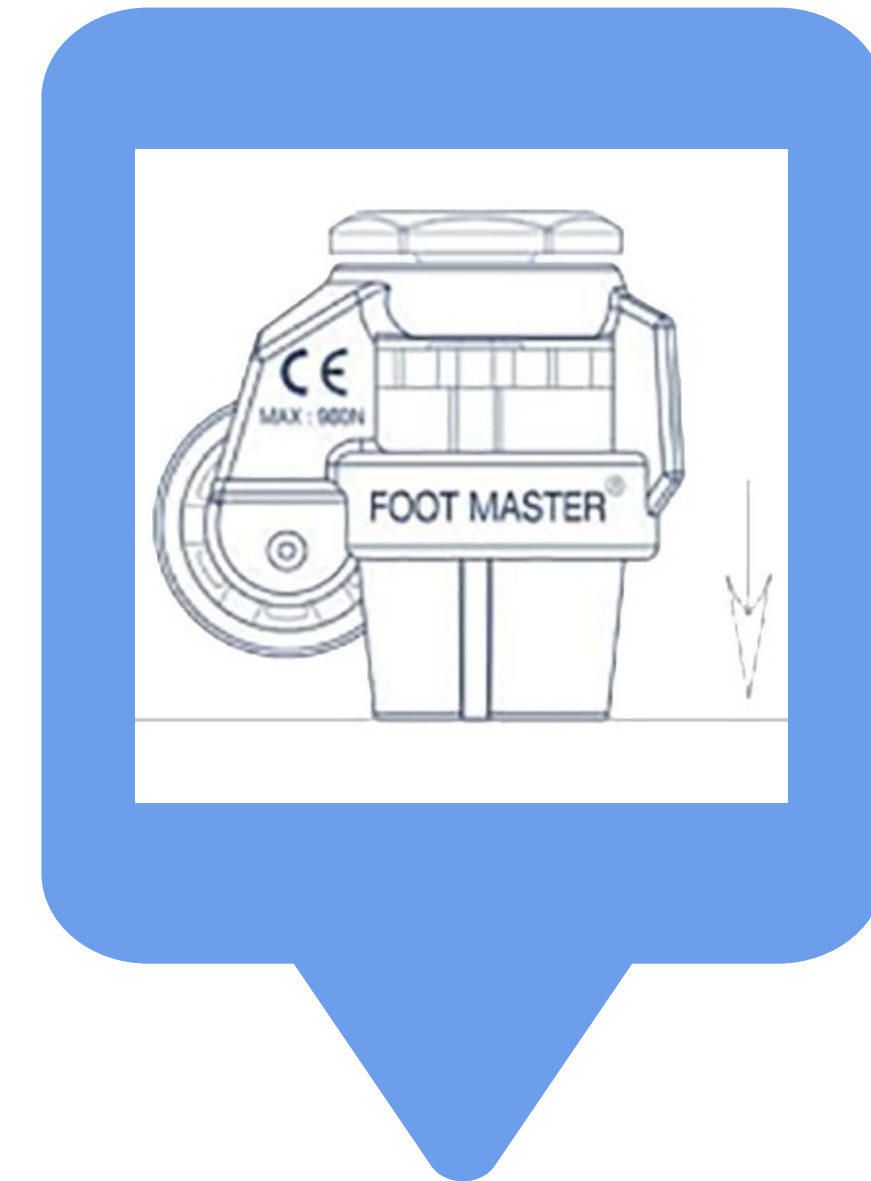
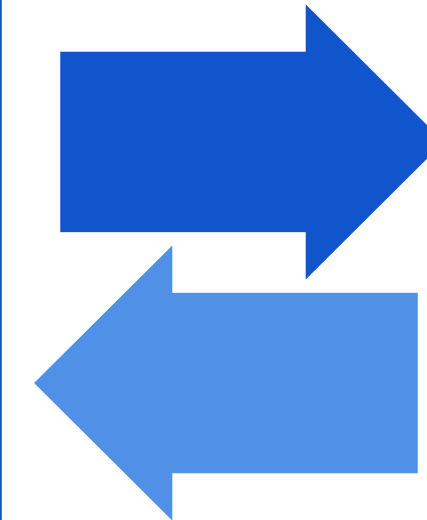

LEVELER

FOOT MASTER® Leveling Casters

Smart Solution for Easy Movement, Leveling Set and Firm Brake



MOBILITY

Casters and wheels attached to the bottom of an object create several advantages such as transporting items & materials efficiently, moving or relocating equipment with ease, and faster deployment of devices and machines.

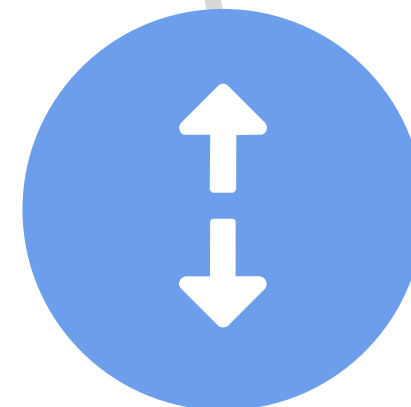

ADJUSTABILITY

Levelers and level mounts can make an object adaptable to uneven floors providing a flat, level surface along a horizontal plane, which delivers optimum balance and achieves accurate calibration.



STABILITY

Foot pads offer expanded capabilities, including anti-vibration protection, shock absorption, flexibility to changing loads, and a firm hold to the ground making equipment completely stationary.

FOOT MASTER® Leveling Casters

GD Series Product Line Handles Various Loads + Various Sizes

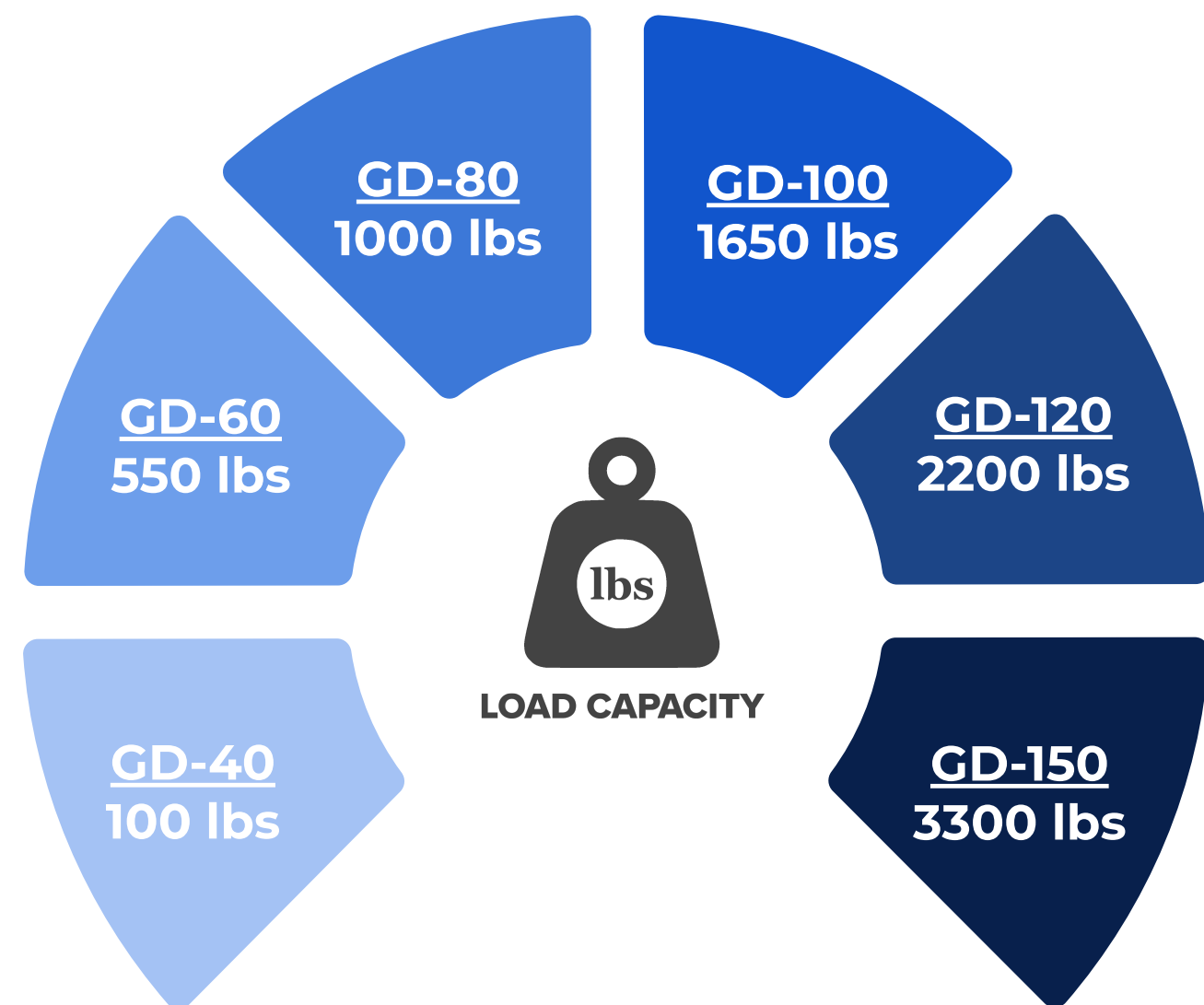
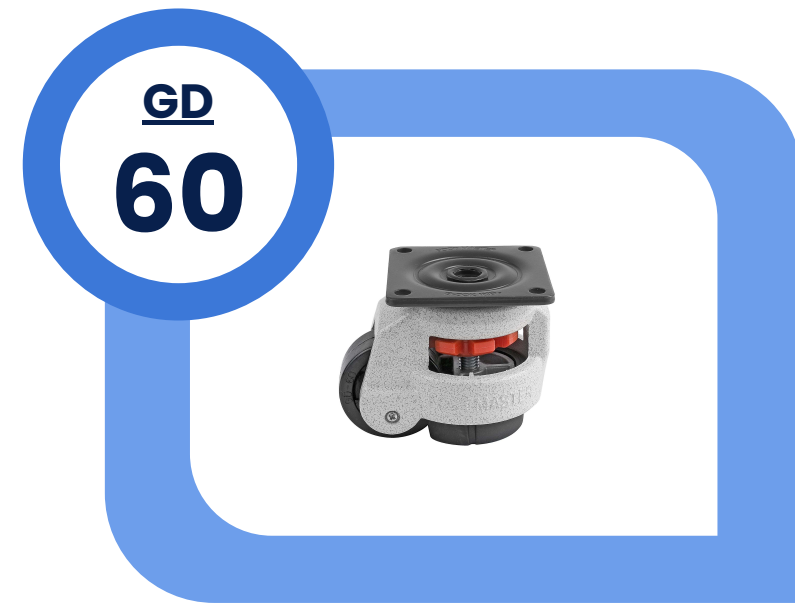

FOOT MASTER® Leveling Casters

Numerous Mounting Options Offered + Available Custom Configurations



GLOBAL METRICATION MAP

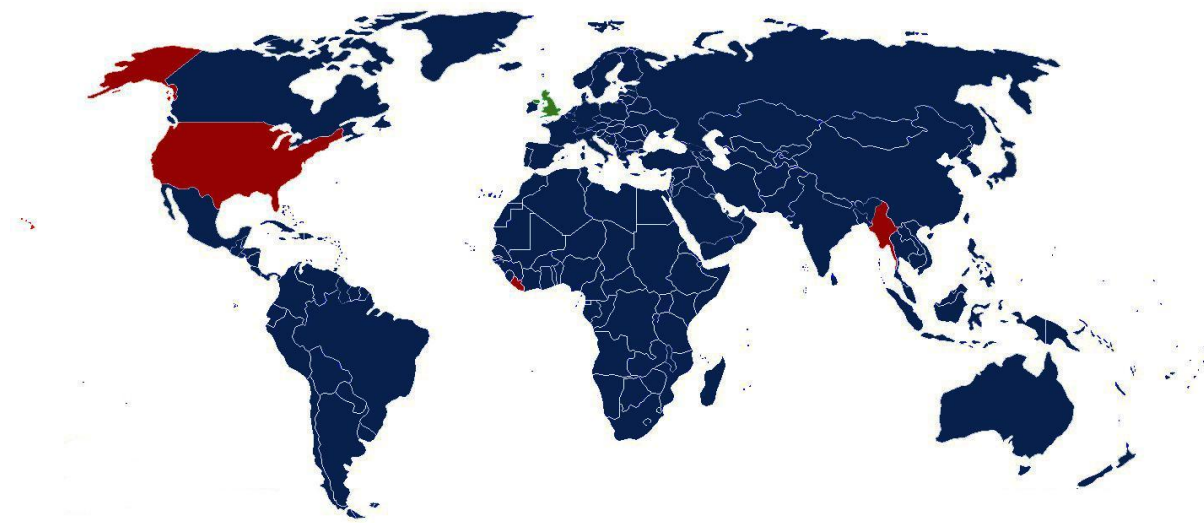

● Metric ● Standard ● Mixed



STANDARD VS METRIC

Most countries use the metric system (SI) as their official system of weights and measures. Led by engineers, global manufacturing companies have converted because the system is precise and decimal-based, while the US has adhered to the standard system.



GLOBAL MARKET DEMAND

FOOT MASTER® believes that meeting the needs of a global market starts with a focus on serving customers and solving problems. GD Series leveling casters can be outfitted with a wide array of mounting options for standard and metric applications. This flexibility creates new capabilities for the food services industry.



MOUNTING VERSATILITY

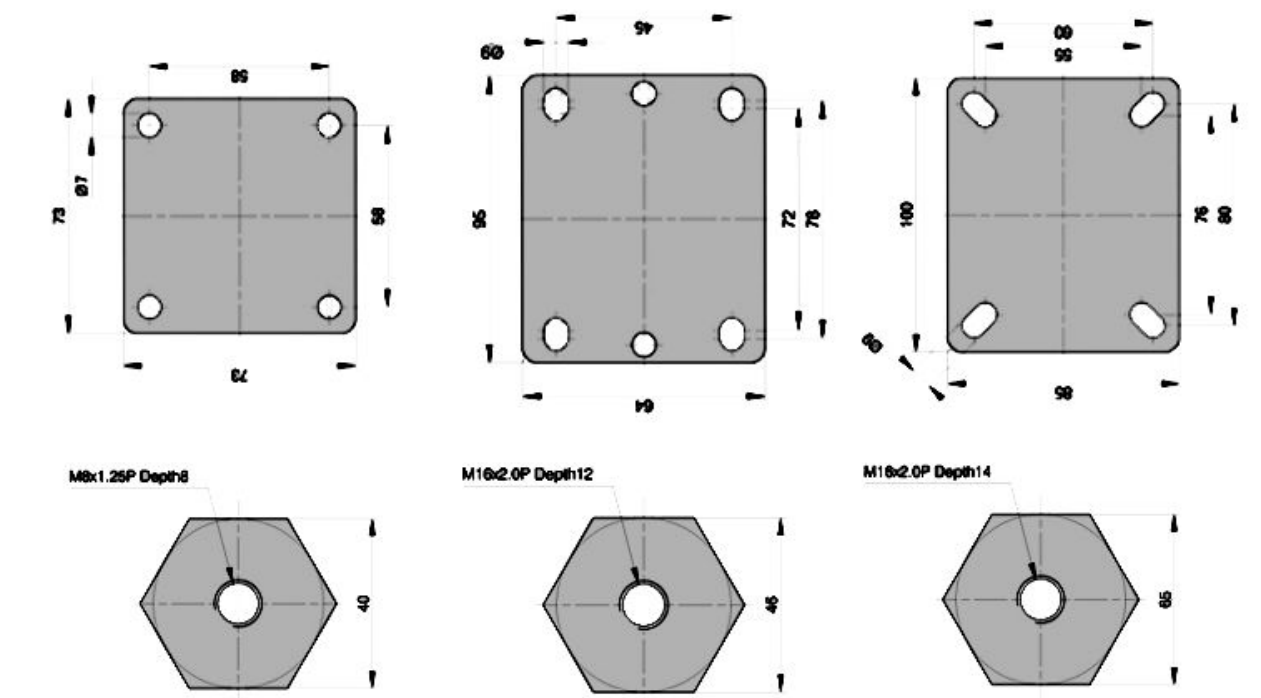

FOOT MASTER® Leveling Casters

Application Specific Wheel + Foot Pad Selections Enable Adaptability



FOOT MASTER® Leveling Casters

An Endless Palette of Color Options to Promote Creativity & Customization



FOOT MASTER® Leveling Casters

Anatomy of the ORIGINAL Leveling Caster + The Standard for Performance

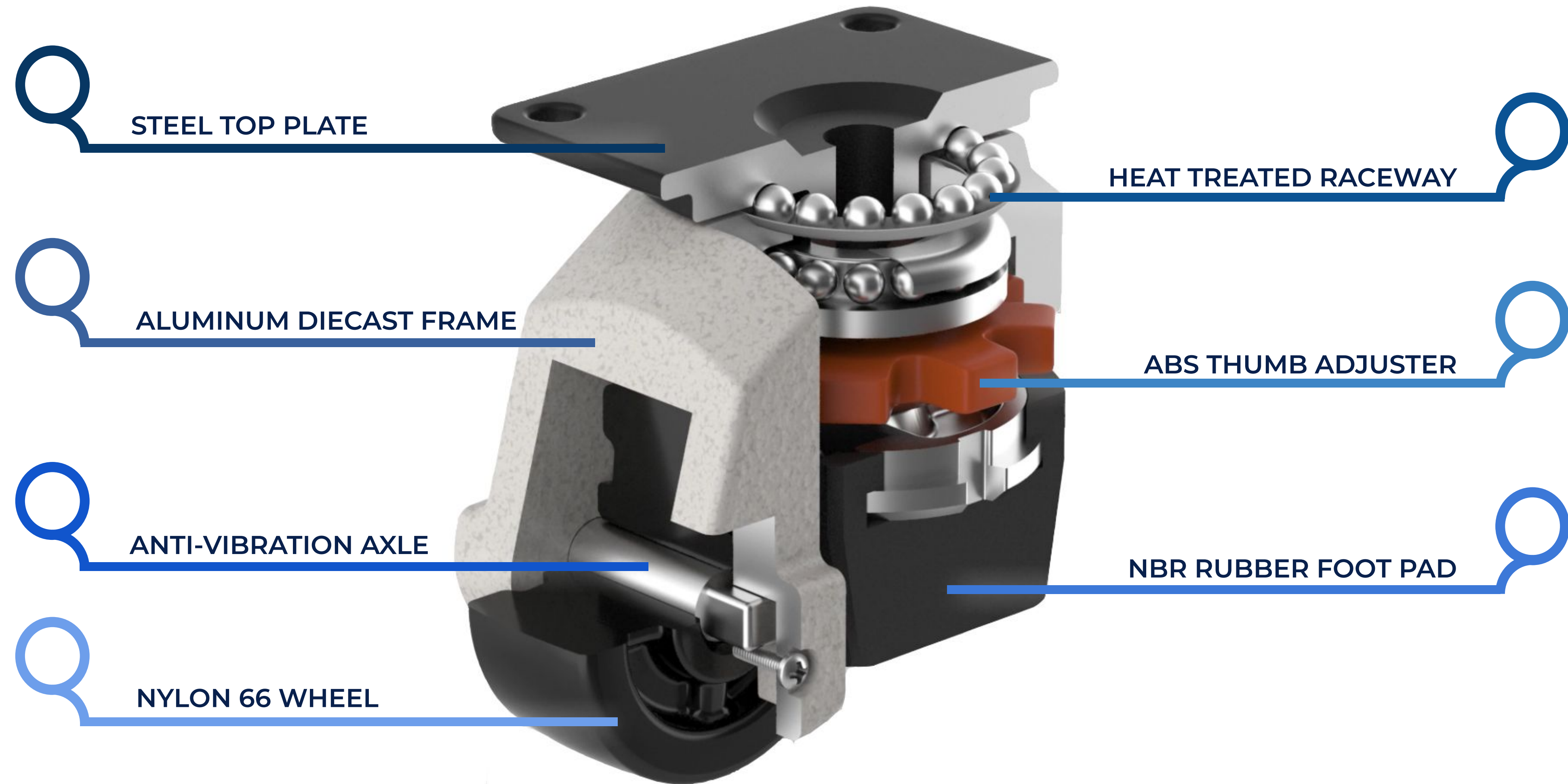

FOOT MASTER® Leveling Casters

Fusing Imagination with Ambition to Proactively Solve Problems

INNOVATION

GD Series leveling casters were designed to empower, engineered with pride, and manufactured to perform. This innovation presents valuable solutions that serve our customers.

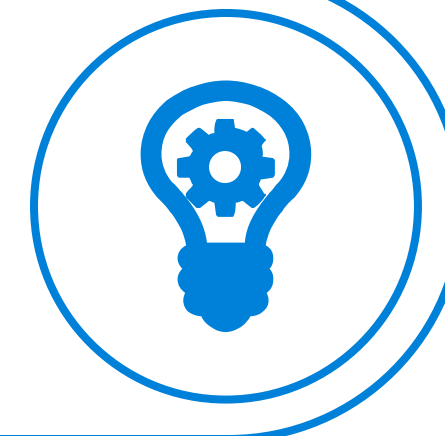

STRENGTH

Solid shaft enables increased load capacity and ease of movement

PRECISION

Machined with square end to prevent rotation and loosening

ACCESSIBLE

Small screws permit wheel removal for easy cleaning and inspection

SUPPORT

Horn legs are formed to cradle the shaft ends and carry the entire load

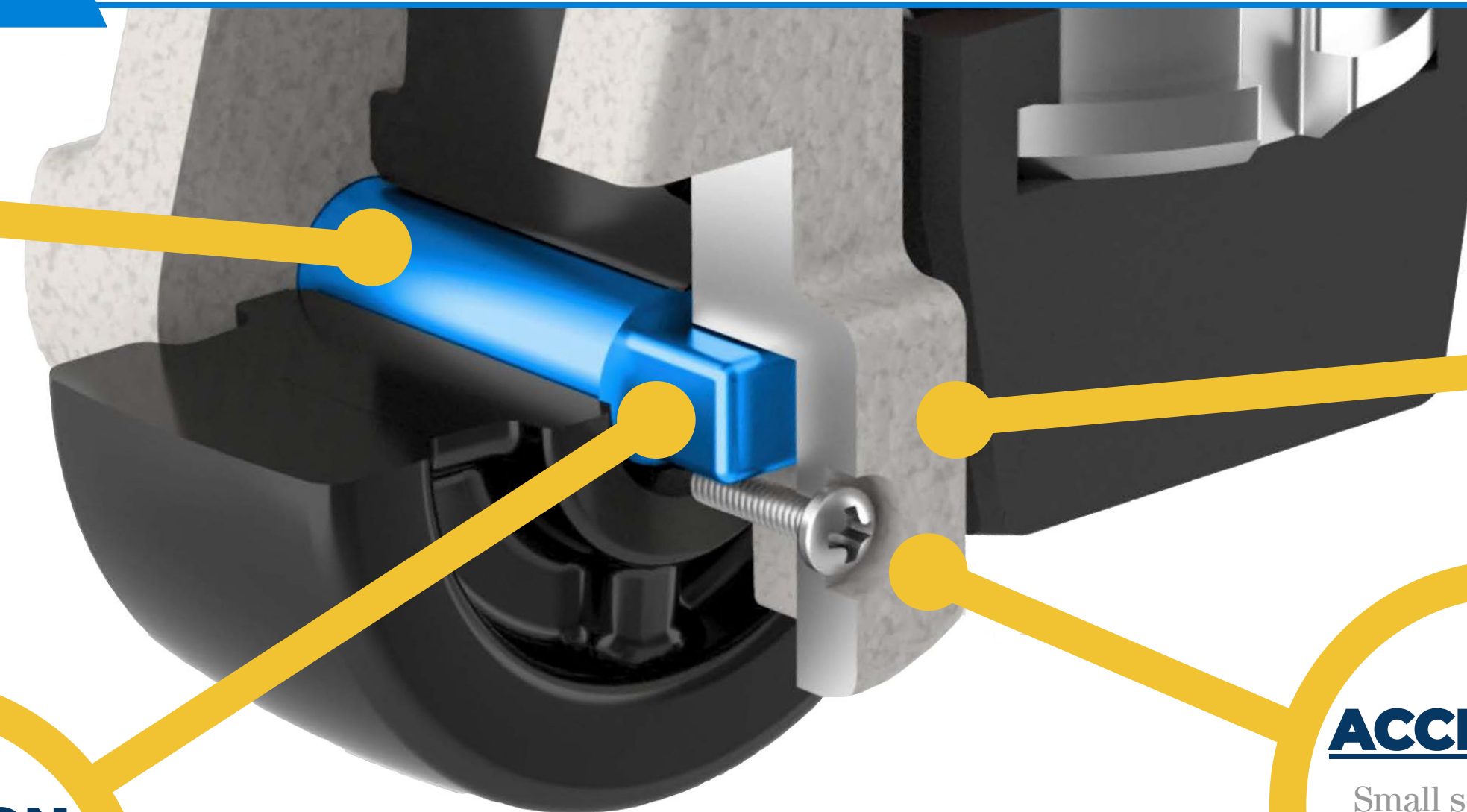

FOOT MASTER® Leveling Casters

Stainless Steel is The Most Common Material Used in Commercial Kitchens



CORROSION RESISTANT

Metal has the capacity to hold binding energy and withstand deterioration and chemical breakdown.



HEAT RESISTANT

Properties can sustain temperatures as low as 14°F, making it ideal for freezers, and as high as 194°F, fitting for kitchen environments.

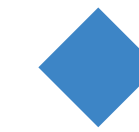

HYGIENIC

A non-porous metal, it possesses a resistance to pitting and does not support the growth of bacteria and pathogens. The quality surface is easy to clean & sanitize.



ENVIRONMENTALLY FRIENDLY

It is 100% reusable and recyclable, as well as neutral to food and beverage items.

FOOT MASTER® Leveling Casters

Diligent To Protect People and The Environment



ROHS COMPLIANT

Restricted materials are hazardous to the environment and pollute landfills, and are dangerous in terms of occupational exposure during manufacturing and recycling.

REACH COMPLIANT

Chemical substances can have a potential negative impact on human health and the environment, and can pose significant risks with devastating effects.

ISO 9001:2015 CERTIFIED

The standard is based on 7 quality management principles, which include strong customer focus, the involvement of top management, and a drive for continual improvement.

FOOT MASTER® Leveling Casters

GD Series Market Domination Incites Competitors To Copy Optimal Design

“It is better to fail in originality than to succeed in imitations.”

- Herman Melville



“Do something wonderful, people may imitate it.”

- Albert Schweitzer

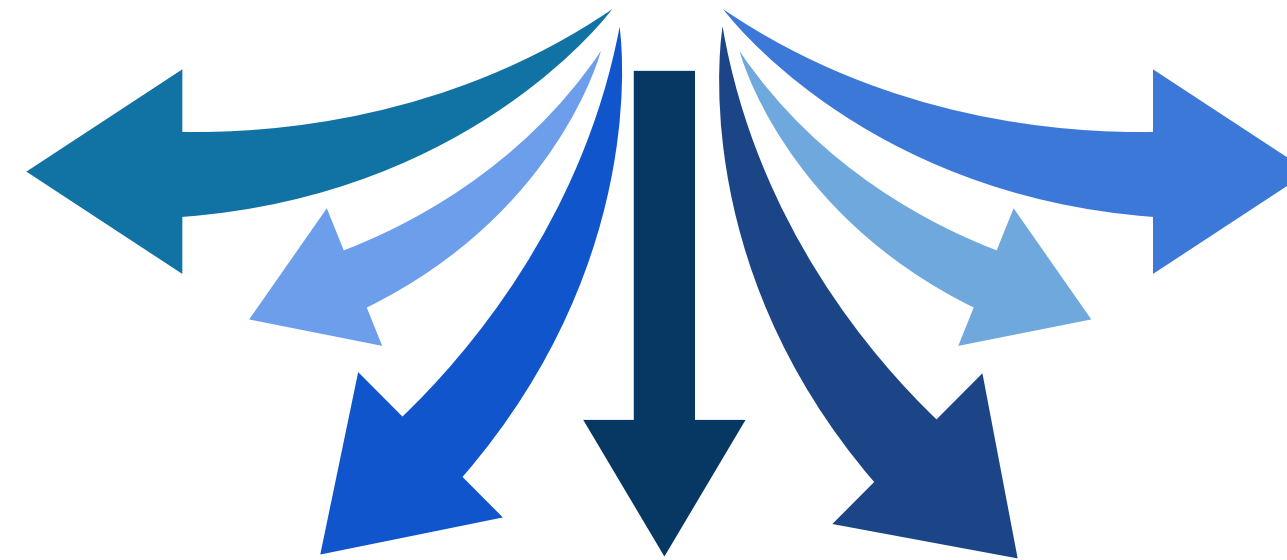

A factory floor with several white plastic foot master molds on a conveyor belt. The molds are arranged in a line, and the background shows industrial machinery and equipment. The scene is brightly lit, and the overall atmosphere is one of a busy manufacturing environment.

THANK YOU

The Pride of Top Quality

FOOT MASTER[®]

North America